

BERKELEY® B4JRMBHS

Cast Iron Impeller

Flanged Case, Mechanical Seal Construction

BEARING FRAME MOUNT

Section	FM
Page	190.2M
Date	March 4, 2013
Supersedes 01/01/04	

Table I

B/M No.	Rotation	Volute Case	Shaft No.	Impeller	Impeller Diameter
B69743	CW	H03843	H05105	L05976	13.50"

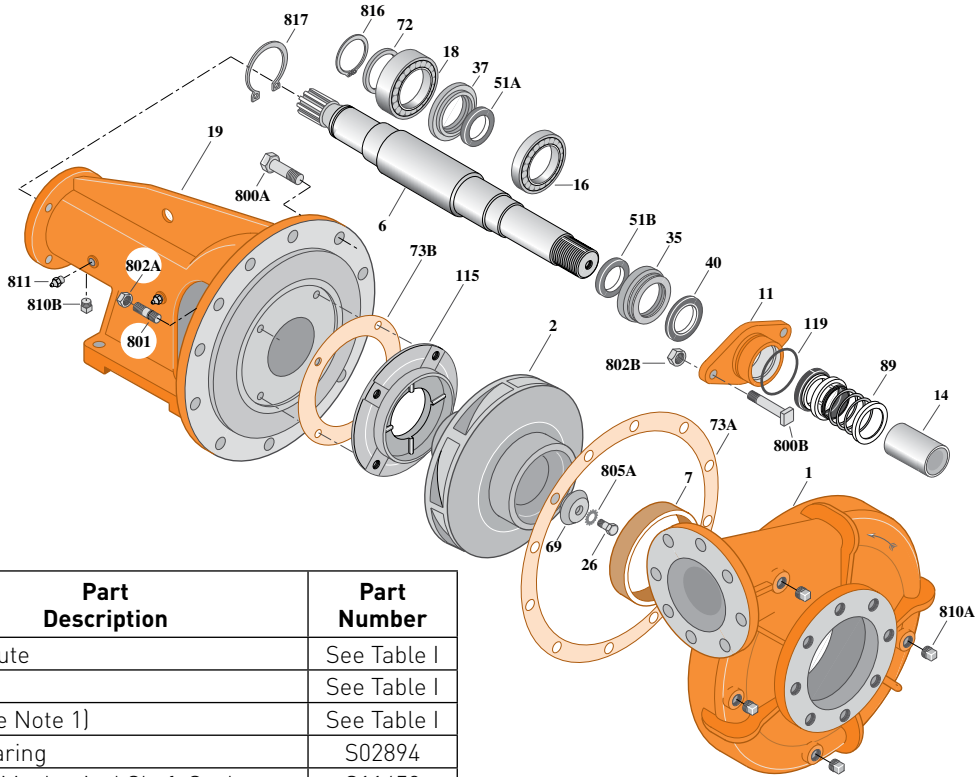

Item No.	Part Description	Part Number
1	Case, Volute	See Table I
2	Impeller	See Table I
6	Shaft [See Note 1]	See Table I
7	Ring, Wearing	S02894
11	Retainer, Mechanical Shaft Seal	S11452
14	Sleeve, Shaft	S05974
16	Bearing, Ball	S15604
18	Bearing, Ball	M10184
19	Frame	H05103
26	Screw, Impeller 1/2-13x1-1/2"	S23623
35	Inner Bearing Cap	M10200
37	Outer Bearing Cap	M10209
40	Slinger, Water	S10964
51A	Seal, Oil	M10210
51B	Seal, Oil	S14765
69	Washer, Impeller	S19275
72	Ring, Thrust	S06519
73A	Gasket, Volute	S06271
73B	Gasket, Balance Ring	S09943
89	Seal, Mechanical Shaft	S32693
115	Ring, Balance	S13591
119	O-Ring	S26471

Item No.	Part Description	Part Number
800A	Capscrew, Hex 5/8-11x1-1/2" [12 Req.]	S26999
800B	Bolt, Sq. Head 1/2-13x2-1/4" [2 Req.]	S23792
801	Stud, 3/8-16x1-1/2" [4 Req.]	S23995
802A	Nut, Hex 3/8-16 [4 Req.]	S23103
802B	Nut, Hex 1/2-13x7/16" [2 Req.]	S23347
805A	Washer, Lock	S23038
810A	Plug, Pipe 1/2 NPT [4 Req.]	S23717
810B	Plug, Pipe 1/4 NPT	S23715
811	Fitting, Grease [2 Req.]	S23670
816	Ring, Retaining	S23016
817	Ring, Retaining	S23025

NOTE 1: Shaft Replacement Kit is not available for this model. Order Replacement Shaft and associated components from above listing.



MAINTENANCE

Impeller Replacement

Threaded Shaft – Frame Mount

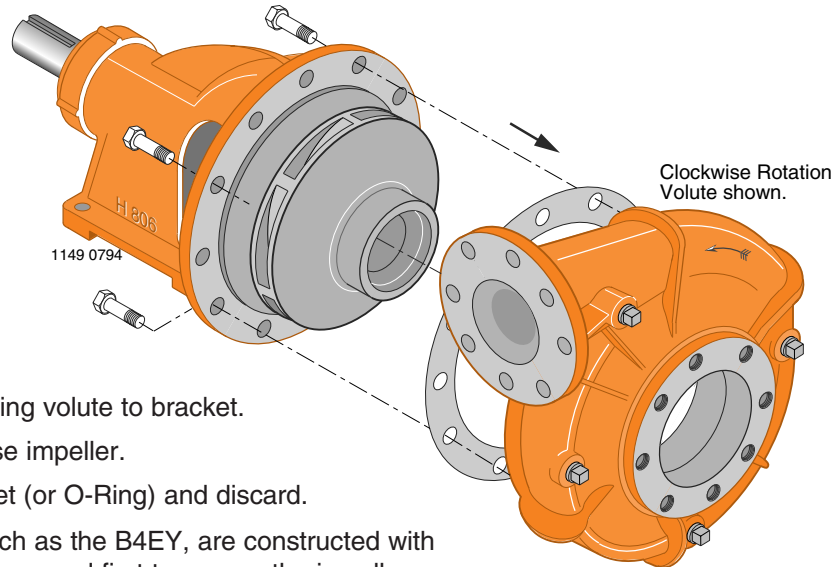

1

- Unfasten hardware holding volute to bracket.
- Remove volute to expose impeller.
- Peel off old volute gasket (or O-Ring) and discard.

NOTE: Certain models such as the B4EY, are constructed with a suction flange which is removed first to access the impeller.

Clockwise rotation as viewed from shaft end.

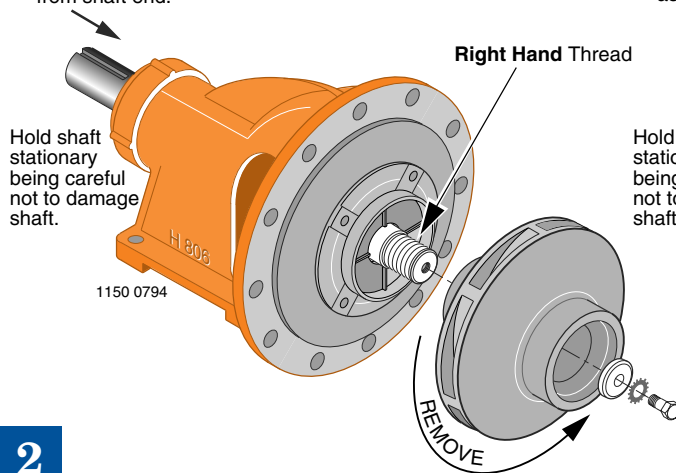

Counter-Clockwise rotation as viewed from shaft end.

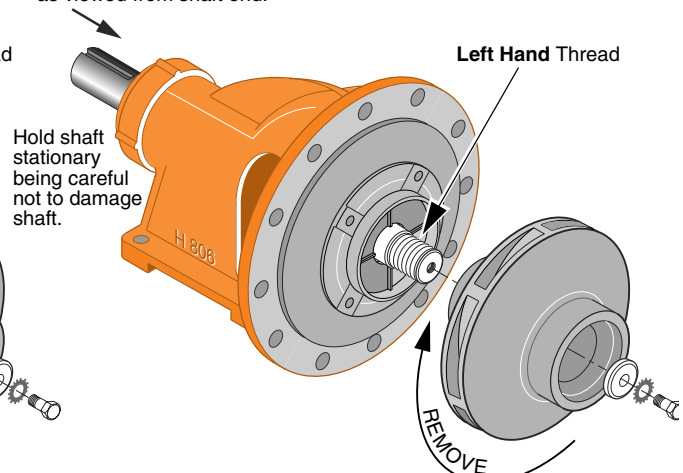

2

- Hold impeller stationary and remove impeller screw and associated hardware.
- Hold shaft stationary and remove impeller by turn-

ing in the direction shown for either clockwise or counter-clockwise pump rotation.

NOTE: Do not use impeller vanes for leverage.

Keyed Shaft

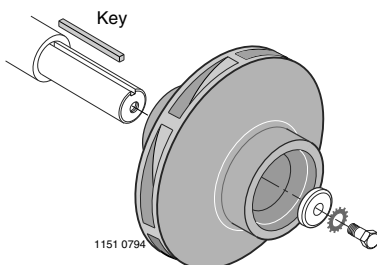

- If motor drive with keyed shaft, refer to mechanical seal disassembly drawing.
- For bearing frame pumps with keyed shaft, consult with factory for approved method of impeller removal.

MAINTENANCE

Packing Ring Replacement

Removal

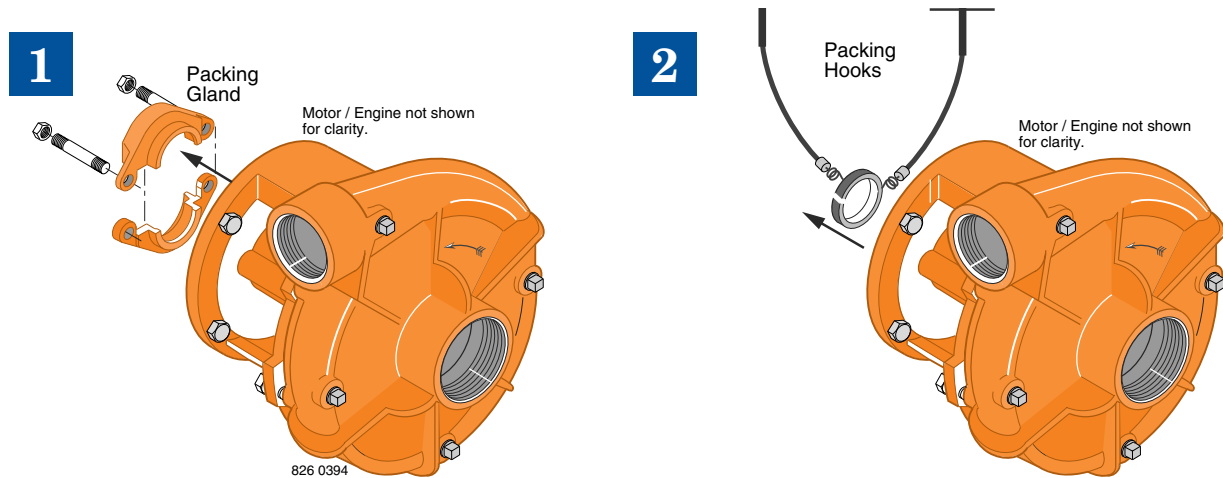

- Unfasten hardware holding Packing Gland in place and slide back on shaft to expose packing rings. A split Packing Gland with threaded studs is shown.
- Remove packing rings from stuffing box using two commercially available Packing Hooks as shown.
- Slide Lantern Ring (if used) back to expose any remaining rings, including metallic. Remove them in the same manner.

Installing New Rings

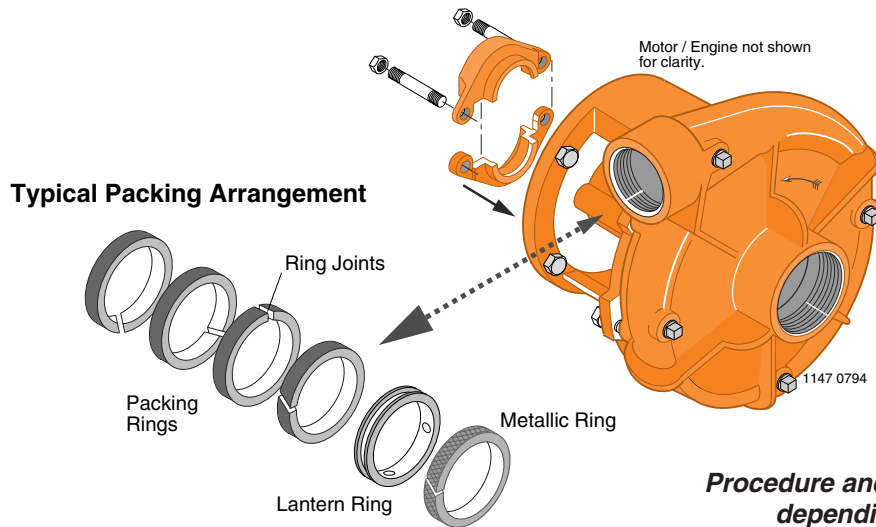

Procedure and parts will vary slightly depending on pump style.

- Clean shaft sleeve and Packing Gland.
- Inspect shaft sleeve for wear, replace if needed.
- Install new packing rings in stuffing box by placing over shaft sleeve and pushing them in as far as they will go.
- Rotate ring joint 90 degrees when installing each ring as shown.
- Slide packing gland into position, then gently and evenly tighten nuts to force rings into place and seat (do not overtighten). Loosen nuts again to hand tight.
- Start primed pump and allow packing to leak liberally.
- Evenly tighten gland nuts one complete turn at a time until leakage is reduced to 40 to 60 drops per minute.

MAINTENANCE

Mechanical Seal Replacement

Disassembly - Motor Drive



1

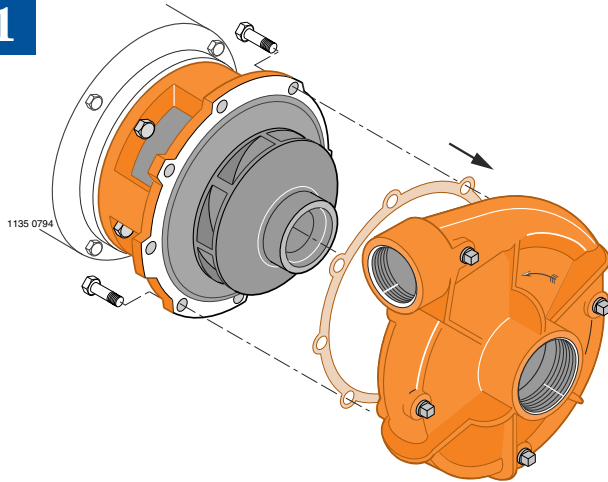

- Unfasten hardware holding volute to bracket.
NOTE: For model B4EY, consult factory for special instructions.
- Remove volute case to expose impeller.

2

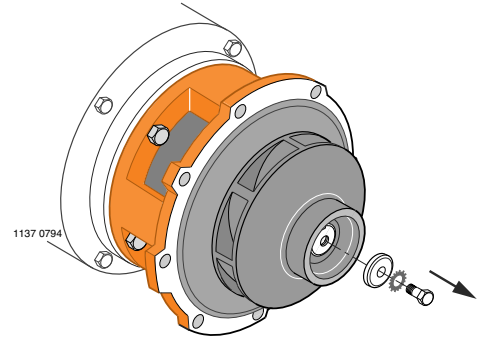

- Peel off old gasket or O-Ring and discard.
- Hold impeller stationary and remove impeller screw and associated hardware.

Procedure and parts will vary slightly depending on pump style.

3

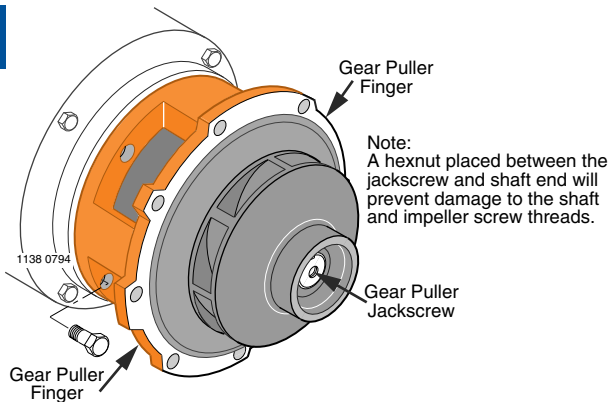

- Remove capscrews holding bracket to motor.
- Install a standard gear puller to shaft end and motor bracket placing puller fingers in the area shown.
- Rotate gear puller jackscrew until impeller clears

4

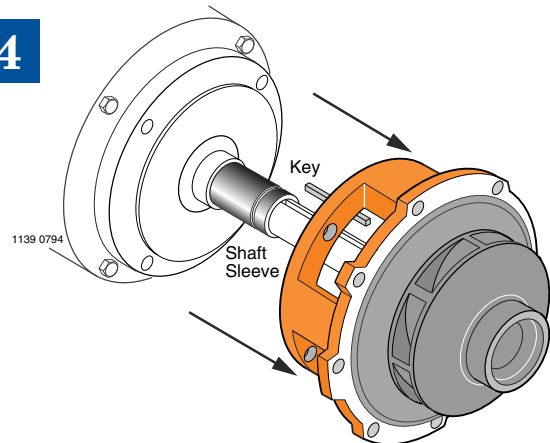

- shaft. Mechanical shaft seal will come off with motor bracket.
- If a seal retaining ring is part of the assembly, it will need to be replaced.

5

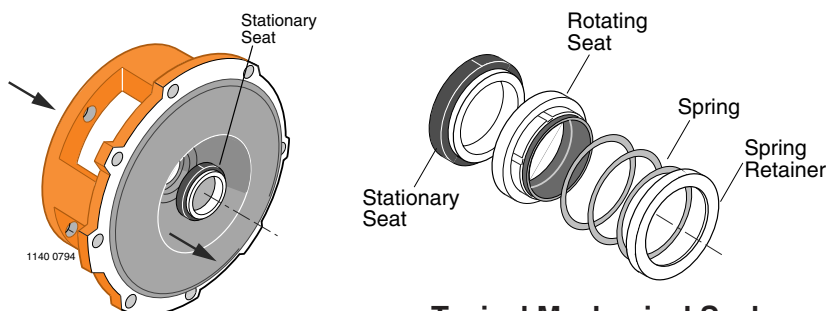

- Push stationary seat out of seal cavity from the back of bracket.
- Clean seal cavity in bracket thoroughly.

Typical Mechanical Seal

MAINTENANCE

Mechanical Seal Replacement

Reassembly – Motor Drive



1

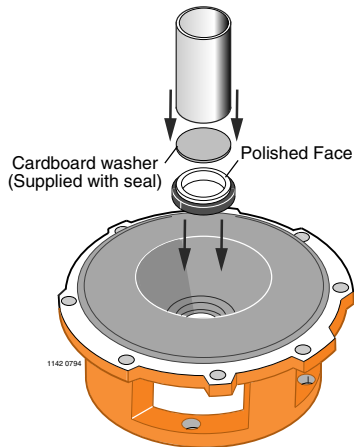

- Place bracket on a smooth, flat surface, pump side up.
- Apply a small amount of mineral oil to O-Ring on stationary seat and press into seal cavity. Cover ceramic face with cardboard washer and press

2

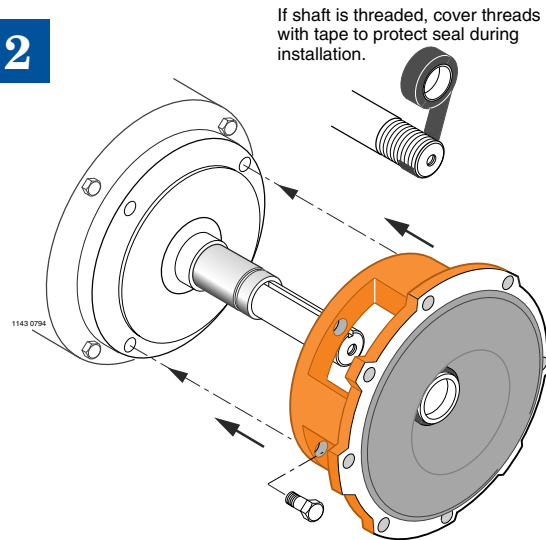

- straight in using a piece of pipe or tubing.
- Reinstall bracket on motor using extreme care not to scratch or chip ceramic face of seal with shaft.

3

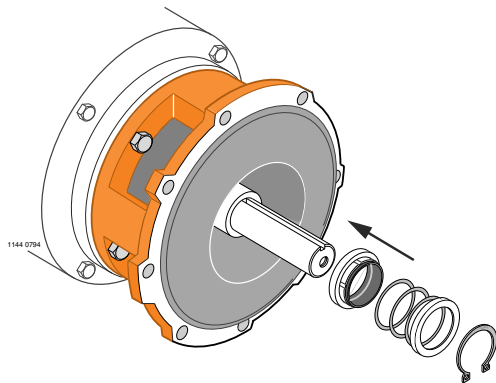

- Apply a small amount of mineral oil to inside diameter of rubber ring in rotating seat and outside of shaft sleeve. Slide rotating seat onto shaft, polished face first, until it is tight against ceramic face.
- Compress seal spring, and install retaining ring (if used) in shaft sleeve groove.

4

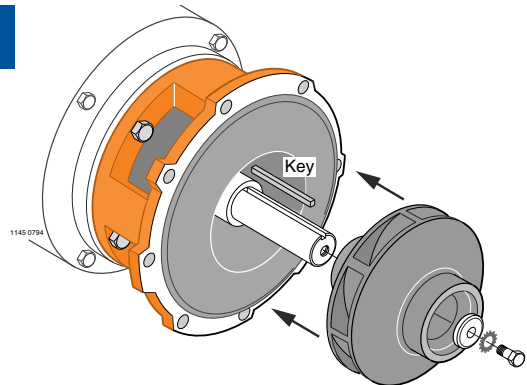

- Place impeller key in motor shaft keyway. Slide impeller on to shaft as far as possible.
- Apply non-permanent thread adhesive to impeller capscrew and shaft threads.
- Install impeller washer, shakeproof lockwasher, and capscrew.

5

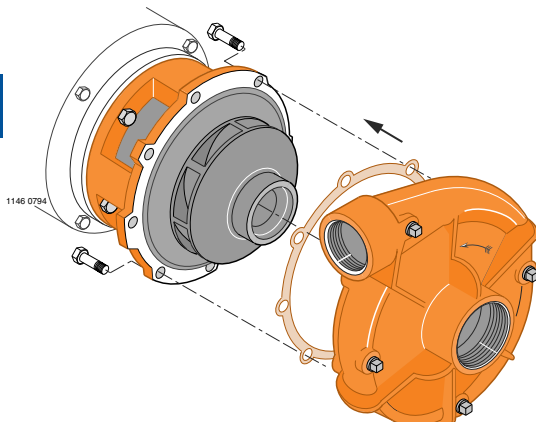

- Install new gasket or O-Ring and volute case onto bracket.
- Install new O-Ring gasket and volute case on to bracket.
- Apply anti-seizing compound to capscrews and tighten securely.

Procedure and parts will vary slightly depending on pump style.